

This manual covers to the following remote control equipment products operation, installation and programming::

Equipment Type	Set Content	Maximum Operating Range
UMB100HShet	receiver UMB100HRhet + 2 remotes UMB100HT	100 m
AN200HShet	receiver UMB100HRhet + 1 remote AN200HT	200 m
UMB100HRhet	UMB100HRhet – receiver only	-

All above listed equipment products include the same receiver model featuring:

- One galvanic separated relay output with NC/NO terminals,
- One OC (open collector) transistor type output for acoustic indication of relay output switch-over,
- Two color LED indicating state of the relay output,
- Comfortable wide range of AC and DC power supply voltages,
- Highly sensitive and selective superhet receiver module,
- Up to 112 hand and keyfob remote control transmitters (further referred to as “remotes”) memory capacity,
- KEELOQ® transmission dynamic encoding system.

Receiver Operation Modes

Receiver allows various operation features depending on selection made by jumpers JP1 & JP2 and programming Monostable (pulse) or Bistable (on/off) relay output mode (step 2 and 3 of programming procedures), as shown in Table 1, below :

Table 1

Jumpers State	Monostable Mode ⁽¹⁾	Bistable Mode ⁽¹⁾
JP2 On JP1 ⁽³⁾	A. Pressing transmitter button sets receiver’s relay output on for programmed time period. Next pressing of the button, while output is on, prolongs set on time of the output.	B. Each pressing of remote transmitter button sets receiver relay output on and off alternately (on/off mode).
JP2 Off, JP1 On	C. Receiver relay output is set on for as long as transmitter button is pressed and sets off, after short delay ⁽²⁾ , on button release.	Not available
JP2 Off JP1 Off	D. Pressing transmitter button 1 sets the output on. Pressing button 2 sets output off. If button 2 is not pressed, relay output sets off after programmed time period ⁽⁴⁾	E. Pressing transmitter button 1 sets output on. Pressing button 2 sets output off.

⁽¹⁾ Output relay Monostable Mode (pulse) or Bistable Mode (on/off) is programmed in steps 2 and 3 of programming procedures.

⁽²⁾ Delayed output set off reduces risk of unwanted interruptions in output set on continuity, due to interferences caused e.g. electric motors. Precise setting of this short delay timing is facilitated by programming 8-fold longer time delay of that needed. Example: to obtain 0.5s set off delay, programmed delay of 4..5s delay must be made (0.5 x 8=4).

Number of remote control transmitters that can be used in this mode is limited to 20.

⁽³⁾ In modes A & B jumper JP1 selects timing of switch-over signal pulses at output S: jumper On – 0.25s pulse, jumper Off – 0.50s pulse. Longer timing of switch-over signal pulses are necessary for certain acoustic signaling devices in which shorter pulses are not recognized properly.

⁽⁴⁾ This mode requires use of hand transmitter with two or more buttons.

KEELOQ® Encoding System

In the system, newly encoded control signal is generated and sent each time transmitter button is pressed. Receiver monitors code changes and responds to signals with new code only. Once received code will not be accepted second time. This allows protection of radio transmission signals from deliberate grabbing and decoding.

Receiver Memory

As each transmitter generates specific dynamic code, receiver must “learn” and memorize individual coding way of every transmitter that will operate with the receiver. Therefore, receiver’s memory capacity is limited. In case of receiver UMB100HRhet capacity is limited to 112 transmitters. Learning 113th transmitter would delete first transmitter in memory, etc. Eliminating one or more lost or stolen transmitters from receiver’s memory requires deleting all transmitters and learning all remaining transmitters again. Deleting one or more transmitters from receiver’s memory is possible only if the transmitters are available.

Receiver Relay Output

Receiver is equipped with galvanic isolated relay output with NO (normally open) and NC (normally closed) wiring terminals. Details are shown on installation diagram included in this manual.

Transistor Output

Receiver features one open collector type (OC) transistor signaling output for connecting to external acoustic siren or light strobe. The output generates two pulses on receiver’s relay output set ON and one pulse on relay output set OFF. Two pulses are generated also when pressed transmitter’s button is used to prolong timing of output set on in monostable mode only (mode A in Table 1). In operation modes D and E (Table 1), in which button 1 sets output on and button 2 sets output off, two pulses are generated each time button 1 is pressed and one pulse each time button 2 is pressed.

LED Indication

Receiver is equipped with two color LED signaling power supply connection and status of relay output. It lights **Red** when power is connected and relay output is not activated. When relay output is activated it lights **Green** for as long as the output stays on.

Receiver Installation

Receiver is designed to operate indoors only. Place of installation should be dry and away from electromagnetic power lines, radio transmitters, metal screening and other devices that may cause interference and reduce operation range. Receiver should be installed well above floor/ground level. It is recommended to test practical operating range of transmitter-receiver set prior to firm installation. Level of hand transmitter signals and unwanted radio interference signals can be tested using optional Elmes RFM indicator.

PROGRAMMING PROCEDURES

Receiver LED low flashing green in confirms properly performed programming procedure. Fast flashing LED in red indicates programming error. Programming procedure must be repeated.

1. Learning transmitter(s) to receiver's memory (maximum 112):

- Press receiver's **PRG1** switch for less than 2 seconds - LED lights green.
- Press shortly hand transmitter button once - receiver LED changes to red.
- Press shortly the same hand transmitter button again.

2. Programming receiver output monostable operation mode (pulse) and output set on timing:

- Press receiver's **PRG1** switch - LED lights green and after two seconds changes to red. Now release the switch.
- Press hand transmitter button. Relay in the receiver sets on. After required pulse time has lapsed press hand transmitter button again. Relay in receiver sets off. After 2 seconds receiver's LED starts flashing green confirming end of the procedure.

3. Programming receiver output bistable (on/off) operation mode:

- Press receiver's **PRG1** switch - LED lights green and after two seconds changes to red. Now release the switch.
- Press transmitter button three times with less than 2 seconds intervals. Receiver LED flashes green confirming end of the procedure.

4. Deleting all transmitters in receiver memory:

Press and hold depressed **PRG1** switch for more than 8 seconds. Receiver LED first lights green. After 2 seconds changes to red and after 6 seconds starts flashing green. Now release the switch. To learn new transmitter(s) follow procedure 1 above.

5. Deleting single transmitter in receiver memory (condition: transmitter to be deleted is available):

- Press receiver's **PRG1** switch for less than 2 seconds - LED lights green.
- Press shortly button of the hand transmitter to be deleted - receiver LED changes to red.
- Perform one of the following steps:
 - Press button of any other Elmes made hand transmitter button, or
 - temporarily disconnect receiver power supply, or
 - wait round 30 seconds till receiver exits programming mode.

Correct performing of this procedure is confirmed by LED flashing red (error indication).

Advice 1: Procedures 2, 3 and 5 can be performed with the use of transmitter learned to the receiver memory.

Advice 2: Time for performing procedures 1 and 5 above is limited to 30 seconds. If the procedures are not completed within this time period receiver exits programming mode and error is indicated.

Specification

Keyfob transm. UMB100HT: radiated power < 5mW, battery: 12V (23A).

Hand transm. AN200HT: radiated power < 10mW, battery: 9V (6F22).

Receiver:

- dynamic code system *KEELOQ*® of Microchip Corp. USA,
- transmitter memory capacity: 112,
- superhet receiver module with sensitivity: -105 dBm,
- power supply range: 10..35VDC, 12..27 VAC, 50mA.
- operating temperature range from -20 to + 40 °C,
- output relay max. power rating: 1A, 120VAC/30VDC,
- monostable output mode timing: from 0,25s up to 4 hours,
- bistable output mode: on/off,
- signal output S (1A/60V max.) OC type,
- sabotage alarm terminals NC type (closed box).



Manufacturer

ELMES ELEKTRONIK, 54-611 Wrocław, Avicenny 2, PL
tel. +48717845961, fax +48717845963

Low battery in transmitters is indicated either by its LED flashing or failing to light.

WARNING! Batteries may contain substances hazardous to human health. Do not place batteries in fire or household waste. Dispose of old batteries properly in accordance with local law regulations. Used batteries can always be disposed of at points of electronic waste collection.

Manufacturer's Limited Warranty

This product carries two year manufacturer's warranty as from the date of purchase. The warranty is limited to the replacement of faulty original parts or repair defects of improper manufacture. Damage, misuse or improper handling by the user or installer as well as any alterations in product's hardware or software caused by unauthorized person violate warranty obligations and all due repair costs will be charged.

Elmes Electronic shall not be liable for any personal or material damage or loss resulting from any of its products direct, indirect or partial use or failure to operate properly.

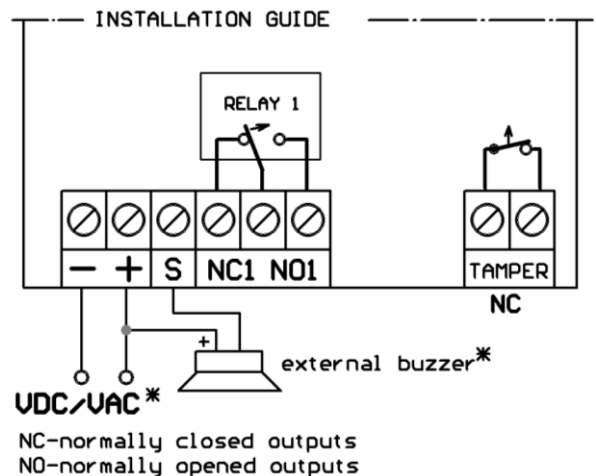

IMPORTANT! Output S must not be directly connected to (+) pole of power supply (see schema).
(* when powering receiver with alternating voltage (VAC) output S must not be used. Not connected to siren.